

Backwash filter assy 30x72, 1.5" CE valve

SET OF EQUIPMENT

- CE 1,5" control valve¹
- Pressure tank 30x72, 4"²

¹CE 1,5" valve assembly (V15CEDT):

- CE 1,5" control valve
- 1,5" meter assembly
- DLFC
- Top stack distributor, insert 50 mm
- Drain fitting 1"
- Power supply
- Funnel
- Valve instruction manual, Instruction manual

²Pressure tank assembly:

- Pressure tank 30x72, 4"
- Adaptor 4" - 2"
- Riser DN 50 mm
- Bottom stack distributor, 4", 50 mm solvent

KEY FEATURES

- Ready sets for different filtration medias
- Basic set ready to work with carbon medias*
- The set is designed for convenient and quick installation

CE CONTROL VALVE KEY FEATURES

- Regeneration control by water volume: delayed regen, immediate, both
- Possibility to change the cycle of regeneration stages and their range of time
- Multilanguage menu: English, German, French, Ukrainian
- Different setting modes are available:
 - twin or duplex configurations
 - up to 6 systems to the system controller
 - 2 external devices simultaneously can be connected

PHYSICAL PARAMETERS

Inlet, outlet	G 1,5"
Drine	G 1"
Operating pressure	2 - 6 bar
Operating temperature	+4...+30 °C
Electrical requirements	230 V, 50 Hz
Electrical power	30 W
Volume of pressure tank	697 L
The volume of the rounded side	80 L
Dry system weight	95 kg



Softener assy w/o media, 1.5" CE valve

Code	Product	Water flow rate**	
		Service, m ³ /h (pressure drop 1 bar)	Backwash, m ³ /h (pressure drop 1,7 bar)
BF3072CE15	Backwash filter assy 30x72, 1.5" CE valve	15,9	11,8

**Only for Clack WS1.5 CE control valves includes meter

ACCESSORIES**

Code	Description
V3017	WS2 Service or Fill Switch Assembly
V3097BSPT	WS1.5" No Hard Water Bypass Male x Female BSPT
V3071BSPT	MAV 1.5 BSPT Revision 2
V3040BSPT-15	WS1.5 Meter Assembly Male x Female NPT 1.5' Meter Cable

** Not included in the basic set.
Can installed as additional equipment

RECOMMENDED MEDIA VOLUME

Code	Description	Volume
CENT1240	Granular activated carbon Centaur 12x40	180 kg
FILTR300	Activated Carbon Filtrasorb 300	175 kg
A8023	Filter-AG PLUS media	367,9 L***
A8014	Filter-AG material	367,9 L***
A8006	Birm filter media	367,9 L***

The volume of filter material depends on the its characteristics.
TDS on filter materials can be found on the official website www.ecosoft.com.
*** Recommended to use support layer, 125 Kg

CONFIGURATIONS

TWIN



TWIN ASSEMBLY PARTS

1. BF3072CE15 - 2 pcs.
2. VLV15BSPT - 1 pcs.
3. Filter media¹

Twin set may operate 2 units with alternative mode (the first unit in operation, the second - in regeneration or stand by) and can produce water during the day at constant flow rate.

KEY FEATURES

- Ensures stable water quality with constant flow
- User friendly installation
- Doesn't create hydraulic shocks

DUPLEX



DUPLEX ASSEMBLY PARTS

1. BF3072CE15 - 2 pcs.
2. DUPLECO15 - 1 pcs.
3. Filter media¹

Duplex set may operate 2 units parallel and can provide double flow rate during peak consumption.

KEY FEATURES

- Double flow rate for peak consumption
- User friendly installation
- Doesn't create hydraulic shocks

2 - 6 SYSTEMS



SET FOR 2...6 UNITS WITH CLACK SYSTEM CONTROLLER

1. BF3072CE125 - 2...6 pcs.
2. Filter media¹
3. WSSYSTCON2* - 1 pcs.

The Clack system controller may operate 2 - 6 units and has 4 operating modes that ensure efficient operation of the set for various needs.

KEY FEATURES

- System Controller may operate 2 - 6 units or be used as a water monitor only
- Clack 1.0", 1.25", 1.5" or 2" control valves may be used
- 4 available operating modes: Progressive flow, Alternator, Series, Random

WSSYSTCON2* - includes a kit for connecting 2 systems. The last number indicates the number of possible connected systems

¹ See "Recommended media volume"

CONNECTIONS

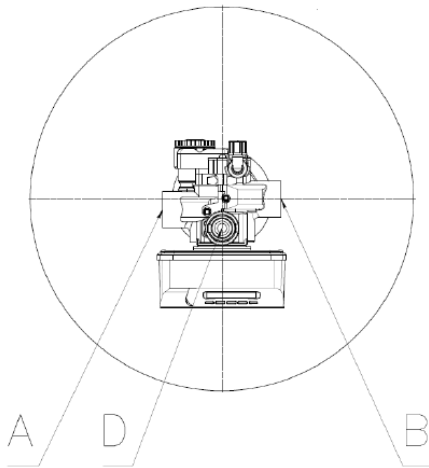

Marking	Nomenclature	Connection	Height
A	Inlet	PH G 1,5"	2160±30
B	Outlet	PH G 1,5"	2160±30
D	Drain	PH G 1"	2370±30

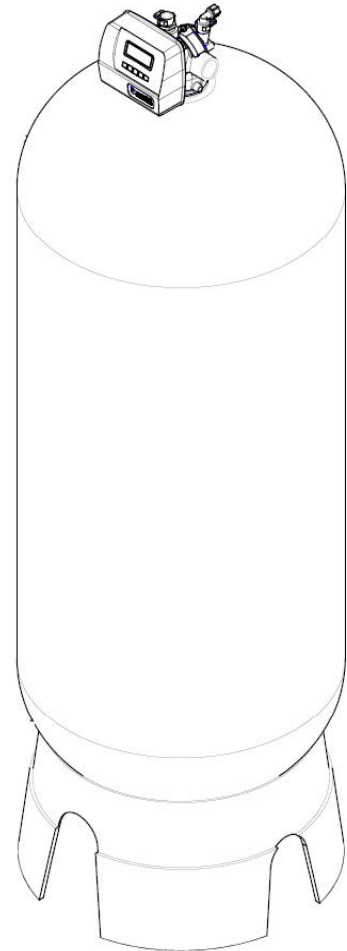

DIMENSIONS OF SYSTEM

