

SINGLE VALVE TWIN 16X65 WATER SOFTENER, 1" CE VALVE

Ready-to-use solution softeners for water with properly selected components. Softeners inside has ion exchange resin which reduced hardness in water.



CE CONTROL VALVE KEY FEATURES

- Regeneration control by water volume: delayed regen, immediate, both
- Possibility to change the cycle of regeneration stages and their range of time
- Multilanguage menu: English, German, French, Ukrainian, Italian*, Polish*

APPLICATIONS

Hot water boilers, laundries, labs & hospitals, drinking water production, breweries & beverage, cooling system, animal farms

KEY FEATURES

- Made in Belgium
- Overflow protection of the brine tank
- Competently selected and installed DLFC and injector
- Pre-configured Ecosoft CE control valve
- Supplied with ion exchange resin
- Designed for convenient installation
- Solid black design*

SET OF EQUIPMENT:

- CE 1" control valve¹
- 2 x pressure tanks 16x65, mounting base - 2,5"²
- Brine tank³
- PC002⁴

¹CE 1" valve assembly (VICEDME):

- CE 1" control valve
- Top stack distributor, 11 segments
- Connection kit 1"
- Power supply
- Injector, DLFC
- Funnel
- Valve instruction manual, Instruction manual
- TT connection kit

²Pressure tanks assembly:

- 2 x pressure tanks 16x65, mounting base - 2,5"
- Riser
- Bottom stack distributor

³Brine tank assembly

- Brine tank 18x36, 146 L
- Brine well assembly (brine valve, overflow set)

⁴PC002 filter material

- Volume resin - 125 L in each tank

* Pressure tank will available from Q3 2025

PHYSICAL PARAMETERS

Inlet, outlet	G 1"	Electrical requirements	230 V, 50 Hz
Drain	G 3/4"	Electrical power	30 W
Brine line	G 3/8"	Volume of pressure tank	183 L
Operating pressure	2 - 6 bar	Volume of brine tank	146 L
Volume capacity**	25.0 m ³	System weight	280 kg
Usage of salt per regeneration	12.5 - 20.0 kg	Operating temperature	+4...+30 °C

** At a hardness of 250 ppm CaCO₃, the salt dose for regeneration is 100 g/l

SINGLE VALVE TWIN 16X65 WATER SOFTENER, 1" CE VALVE

Code	Product	Water flow rate	
		Operating, m ³ /h	Maximum, m ³ /h
FU1665CETWIN	Single valve TWIN 16x65 water softener, 1" CE valve	5.2	6.2

ACCESSORIES***

Code	Description
V3006	WS1 Bypass Assembly
V3009	WS1 Auxiliary Microswitch Assembly
V3191-01	WS1 Bypass Vertical Adapter Assy

*** Not included in the basic set. Can installed as additional equipment

RAW WATER QUALITY REQUIREMENTS

Hardness, ppm CaCO ₃	750
Iron, mg/L	0.2
Manganese, mg/L	0.05
Chemical Oxygen Demand, mg/L O ₂	5
Ammonium, mg/L	0.5

CONNECTIONS

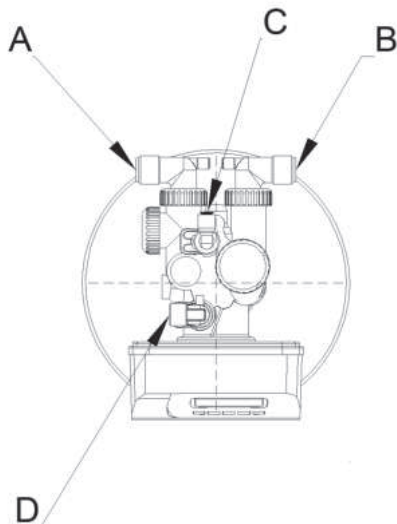

Marking	Nomenclature	Connection	Height
A	Outlet	PH G 1"	1760±30
B	Inlet	PH G 1"	1760±30
C	Brine line	PH G 3/8"	1855±30
D	Drain	PH G 3/4"	1865±30

DIMENSIONS OF SYSTEM

