

BI-BLOCK 14X65 WATER SOFTENER, 1" CE VALVE

Ready-to-use solution softeners for water with properly selected components. Softeners inside has ion exchange resin which reduced hardness in water.



CE CONTROL VALVE KEY FEATURES

- Regeneration control by water volume: delayed regen, immediate, both
- Possibility to change the cycle of regeneration stages and their range of time
- Multilanguage menu: English, German, French, Ukrainian, Italian*, Polish*
- Different setting modes are available:
 - Twin or duplex configurations
 - Up to 8 systems to the system controller
 - 2 external devices simultaneously can be connected

APPLICATIONS

Households, hot water boilers, schools, laundries, café & restaurants, hotels, labs & hospitals, drinking water production, breweries & beverage, cooling system, animal farms

KEY FEATURES

- Made in Belgium
- Overflow protection of the brine tank
- Selected and installed DLFC and injector
- Pre-configured Ecosoft CE control valve
- Supplied with ion exchange resin
- Designed for convenient installation
- Solid black design*

SET OF EQUIPMENT:

- CE 1" control valve¹
- Pressure tank 14x65, mounting base - 2,5"²
- Brine tank³
- PC002⁴

¹CE 1" valve assembly (V1CEDME):

- CE 1" control valve
- Top stack distributor, 11 segments
- Connection kit 1"
- Power supply
- Injector, DLFC
- Funnel
- Valve instruction manual, Instruction manual

²Pressure tank assembly:

- Pressure tank 14x65, mounting base - 2,5"
- Riser
- Bottom stack distributor

³Brine tank assembly

- Brine tank 18x36, 146 L
- Brine well assembly (brine valve, overflow set)

⁴PC002 filter material

- Volume resin - 100 L

PHYSICAL PARAMETERS

Inlet, outlet	G 1"	Electrical requirements	230 V, 50 Hz
Drain	G 3/4"	Electrical power	30 W
Brine line	G 3/8"	Volume of pressure tank	150 L
Operating pressure	2 - 6 bar	Volume of brine tank	146 L
Volume capacity**	20.0 m ³	System weight	125 kg
Usage of salt per regeneration	10.0 - 16.0 kg	Operating temperature	+4...+30 °C

** At a hardness of 250 ppm CaCO₃, the salt dose for regeneration is 100 g/l

BI-BLOCK 14X65 WATER SOFTENER, 1" CE VALVE

Code	Product	Water flow rate	
		Operating, m ³ /h	Maximum, m ³ /h
FU1465CE	Bi-Block 14x65 water softener, 1" CE valve	4.0	5.0

ACCESSORIES***

Code	Description
V3006	WS1 Bypass Assembly
V3009	WS1 Auxiliary Microswitch Assembly
V3070FM	Bypass shut-off valve during regeneration (no-Bypass valve) for 1" and 1.25" systems
V3069MM-01	Water Specialist 1" & 1.25" Motorized Alternating Valve
V3191-01	WS1 Bypass Vertical Adapter Assy

*** Not included in the basic set. Can installed as additional equipment

RAW WATER QUALITY REQUIREMENTS

Hardness, ppm CaCO ₃	750
Iron, mg/L	0.2
Manganese, mg/L	0.05
Chemical Oxygen Demand, mg/L O ₂	5
Ammonium, mg/L	0.5

DOUBLE VALVE TWIN



DOUBLE VALVE TWIN ASSEMBLY PARTS

1. FU1465CE — 2 pcs.
2. V3069MM-01 — 1 pc.
3. V3191-01 — 2 pcs.

Single valve twin set may operate 2 units with alternative mode (the first unit in operation, the second — in regeneration or stand by) and can produce water during the day at constant flow rate.

KEY FEATURES

- Ensures stable water quality with constant flow 24/7
- User friendly installation
- Doesn't create hydraulic shocks

DUPLEX VALVE



DUPLEX VALVE ASSEMBLY PARTS

1. FU1465CE — 2 pcs.
2. V3070FM — 2 pcs.
3. 1PROVODDUP — 2 pcs.
4. V3009 — 2 pcs.

Duplex valve set may operate 2 units parallel and can provide double flow rate during peak consumption.

KEY FEATURES

- Double flow rate for peak consumption
- User friendly installation
- Doesn't create hydraulic shocks

MULTI-SYSTEMS



SET FOR 2...8 UNITS WITH CLACK SYSTEM CONTROLLER

1. FU1465CE — 2...8 pcs.
2. WSSYSTCON2* — 1 pcs.
3. V3070FM — 2...8 pcs.

The Clack system controller may operate 2 - 8 units and has 4 operating modes that ensure efficient operation of the set for various needs.

KEY FEATURES

- System Controller may operate 2 — 8 units or be used as a water monitor only
- Clack WS1.0, WS1.25, WS1.5 or WS2 control valves may be used
- 4 available operating modes: Progressive flow, Alternator, Series, Random

WSSYSTCON2* — includes a kit for connecting 2 systems. The last number indicates the number of possible connected systems

CONNECTIONS

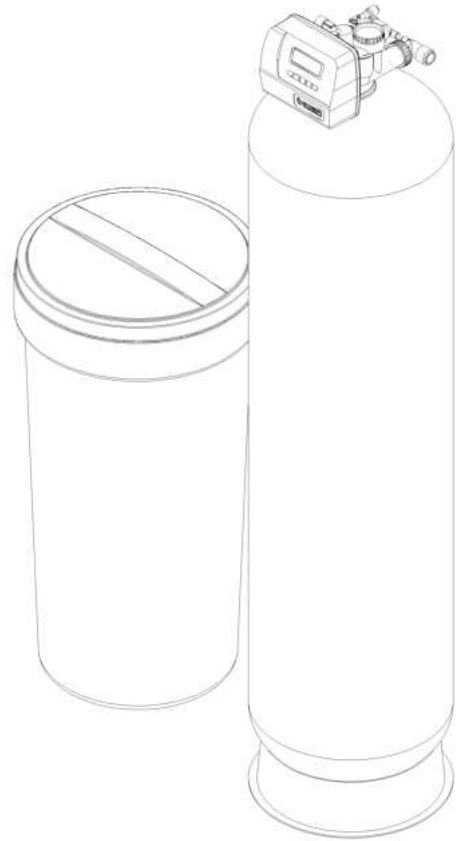
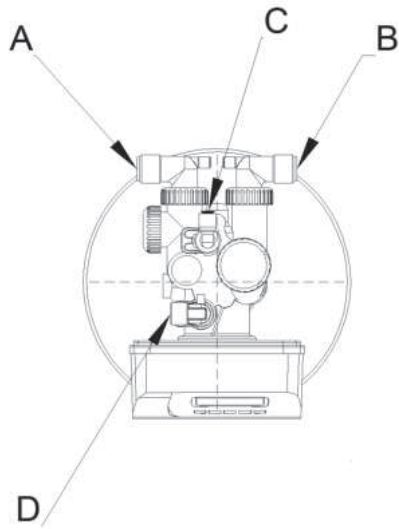

Marking	Nomenclature	Connection	Height
A	Outlet	PH G 1"	1760±30
B	Inlet	PH G 1"	
C	Brine line	PH G 3/8"	1855±30
D	Drain	PH G 3/4"	1865±30

DIMENSIONS OF SYSTEM

