

## BI-BLOCK 12X52 WATER SOFTENER, 1" CE VALVE

Ready-to-use solution softeners for water with properly selected components. Softeners inside has ion exchange resin which reduced hardness in water.



### CE CONTROL VALVE KEY FEATURES

- Regeneration control by water volume: delayed regen, immediate, both
- Possibility to change the cycle of regeneration stages and their range of time
- Multilanguage menu: English, German, French, Ukrainian, Italian\*, Polish\*
- Different setting modes are available:
  - Twin or duplex configurations
  - Up to 8 systems to the system controller
  - 2 external devices simultaneously can be connected

### APPLICATIONS

Households, hot water boilers, schools, laundries, café & restaurants, hotels, labs & hospitals, drinking water production, breweries & beverage, cooling system, animal farms

### KEY FEATURES

- Made in Belgium
- Overflow protection of the brine tank
- Selected and installed DLFC and injector
- Pre-configured Ecosoft CE control valve
- Supplied with ion exchange resin
- Designed for convenient installation
- Solid black design\*

### SET OF EQUIPMENT:

- CE 1" control valve<sup>1</sup>
- Pressure tank 12×52, mounting base – 2,5"<sup>2</sup>
- Brine tank<sup>3</sup>
- PC002<sup>4</sup>

#### <sup>1</sup>CE 1" valve assembly (VICEDME):

- CE 1" control valve
- Top stack distributor, 11 segments
- Connection kit 1"
- Power supply
- Injector, DLFC
- Funnel
- Valve instruction manual, Instruction manual

#### <sup>2</sup>Pressure tank assembly:

- Pressure tank 12×52, mounting base – 2,5"
- Riser
- Bottom stack distributor

#### <sup>3</sup>Brine tank assembly

- Brine tank 15×17×36, 125 L
- Brine well assembly (brine valve, overflow set)

#### <sup>4</sup>PC002 filter material

- Volume resin – 62 L

## PHYSICAL PARAMETERS

Inlet, outlet	G 1"	Electrical requirements	230 V, 50 Hz
Drain	G 3/4"	Electrical power	30 W
Brine line	G 3/8"	Volume of pressure tank	88 L
Operating pressure	2 - 6 bar	Volume of brine tank	125 L
Volume capacity**	12.4 m <sup>3</sup>	System weight	82 kg
Usage of salt per regeneration	6.2 - 10.0 kg	Operating temperature	+4...+30 °C

\*\* At a hardness of 250 ppm CaCO<sub>3</sub>, the salt dose for regeneration is 100 g/l

## BI-BLOCK 12X52 WATER SOFTENER, 1" CE VALVE

Code	Product	Water flow rate	
		Operating, m <sup>3</sup> /h	Maximum, m <sup>3</sup> /h
FU1252CE	Bi-Block 12×52 water softener, 1" CE valve	2.9	3.6

## ACCESSORIES\*\*\*

Code	Description
V3006	WS1 Bypass Assembly
V3009	WS1 Auxiliary Microswitch Assembly
V3070FM	Bypass shut-off valve during regeneration (no-Bypass valve) for 1" and 1.25" systems
V3069MM-01	Water Specialist 1" & 1.25" Motorized Alternating Valve
V3191-01	WS1 Bypass Vertical Adapter Assy

\*\*\* Not included in the basic set. Can installed as additional equipment

## RAW WATER QUALITY REQUIREMENTS

Hardness, ppm CaCO <sub>3</sub>	750
Iron, mg/L	0.2
Manganese, mg/L	0.05
Chemical Oxygen Demand, mg/L O <sub>2</sub>	5
Ammonium, mg/L	0.5

## DOUBLE VALVE TWIN



### DOUBLE VALVE TWIN ASSEMBLY PARTS

1. FU1252CE — 2 pcs.
2. V3069MM-01 — 1 pc.
3. V3191-01 — 2 pcs.

Single valve twin set may operate 2 units with alternative mode (the first unit in operation, the second — in regeneration or stand by) and can produce water during the day at constant flow rate.

### KEY FEATURES

- Ensures stable water quality with constant flow 24/7
- User friendly installation
- Doesn't create hydraulic shocks

## DUPLEX VALVE



### DUPLEX VALVE ASSEMBLY PARTS

1. FU1252CE — 2 pcs.
2. V3070FM — 2 pcs.
3. 1PROVODDUP — 2 pcs.
4. V3009 — 2 pcs.

Duplex valve set may operate 2 units parallel and can provide double flow rate during peak consumption.

### KEY FEATURES

- Double flow rate for peak consumption
- User friendly installation
- Doesn't create hydraulic shocks

## MULTI-SYSTEMS



### SET FOR 2...8 UNITS WITH CLACK SYSTEM CONTROLLER

1. FU1252CE — 2...8 pcs.
2. WSSYSTCON2\* — 1 pcs.
3. V3070FM — 2...8 pcs.

The Clack system controller may operate 2 – 8 units and has 4 operating modes that ensure efficient operation of the set for various needs.

### KEY FEATURES

- System Controller may operate 2 — 8 units or be used as a water monitor only
- Clack WS1.0, WS1.25, WS1.5 or WS2 control valves may be used
- 4 available operating modes: Progressive flow, Alternator, Series, Random

**WSSYSTCON2\*** — includes a kit for connecting 2 systems. The last number indicates the number of possible connected systems

## CONNECTIONS

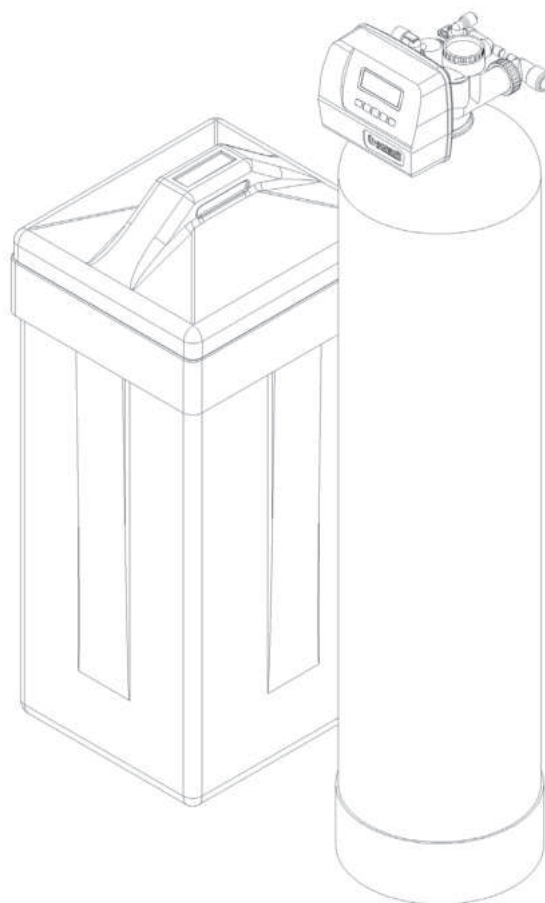
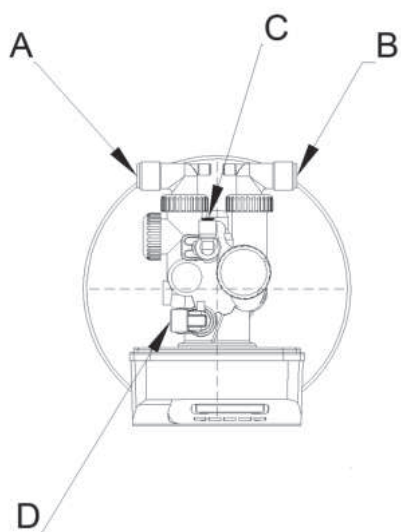

Marking	Nomenclature	Connection	Height
A	Outlet	PH G 1"	1395±30
B	Inlet	PH G 1"	
C	Brine line	PH G 3/8"	1485±30
D	Drain	PH G 3/4"	1495±30

## DIMENSIONS OF SYSTEM

