

## SINGLE VALVE TWIN 13X54 WELL WATER SOFTENER, 1" CE VALVE

Ready-to-use solution softeners well for water with properly selected components. Softeners inside has ion exchange resin which reduced hardness in water.



### CE CONTROL VALVE KEY FEATURES

- Regeneration control by water volume: delayed regen, immediate, both
- Possibility to change the cycle of regeneration stages and their range of time
- Multilanguage menu: English, German, French, Ukrainian, Italian\*, Polish\*

\* Pressure tank will available from Q3 2025

### APPLICATIONS

Hot water boilers, laundries, labs & hospitals, drinking water production, breweries & beverage, cooling system, animal farms

### KEY FEATURES

- Made in Belgium
- Overflow protection of the brine tank
- Competently selected and installed DLFC and injector
- Pre-configured Ecosoft CE control valve
- Supplied with ECOMIX® C
- Designed for convenient installation
- Solid black design\*

### SET OF EQUIPMENT:

- CE 1" control valve<sup>1</sup>
- 2 x pressure tanks 13x54, mounting base – 2,5"<sup>2</sup>
- Brine tank<sup>3</sup>
- ECOMIX® C<sup>4</sup>

#### <sup>1</sup>CE 1" valve assembly (VICEDME):

- CE 1" control valve
- Top stack distributor, 11 segments
- Connection kit 1"
- Power supply
- Injector, DLFC
- Funnel
- Valve instruction manual, Instruction manual
- TT connection kit

#### <sup>2</sup>Pressure tanks assembly:

- 2 x pressure tanks 13x54, mounting base – 2,5"
- Riser
- Bottom stack distributor

#### <sup>3</sup>Brine tank assembly

- Brine tank 15x17x36, 125 L
- Brine well assembly (brine valve, overflow set)

#### <sup>4</sup>Ecomix C filter material

- Volume ECOMIX® – 62 L in each tank

## PHYSICAL PARAMETERS

Inlet, outlet	G 1"	Electrical requirements	230 V, 50 Hz
Drain	G 3/4"	Electrical power	30 W
Brine line	G 3/8"	Volume of pressure tank	105 L
Operating pressure	2 – 6 bar	Volume of brine tank	125 L
Volume capacity**	7.4 m <sup>3</sup>	System weight	155 kg
Usage of salt per regeneration	6.2 – 10.0 kg	Operating temperature	+4...+30 °C

\*\* At a hardness of 250 ppm CaCO<sub>3</sub>, the salt dose for regeneration is 100 g/l

## SINGLE VALVE TWIN 13X54 WELL WATER SOFTENER, 1" CE VALVE

Code	Product	Water flow rate	
		Operating, m <sup>3</sup> /h	Maximum, m <sup>3</sup> /h
FK1354CEMIXCTWIN	Single valve TWIN 13x54 well water softener, 1" CE valve	2.2	2.5

## ACCESSORIES\*\*\*

Code	Description
V3006	WS1 Bypass Assembly
V3009	WS1 Auxiliary Microswitch Assembly
V3191-01	WS1 Bypass Vertical Adapter Assy

\*\*\* Not included in the basic set. Can installed as additional equipment

## RAW WATER QUALITY REQUIREMENTS

Hardness, ppm CaCO <sub>3</sub>	750
Iron, mg/L	15
Manganese, mg/L	3
Chemical Oxygen Demand, mg/L O <sub>2</sub>	20 (Reduces by 80%)
Ammonium, mg/L	4

## CONNECTIONS

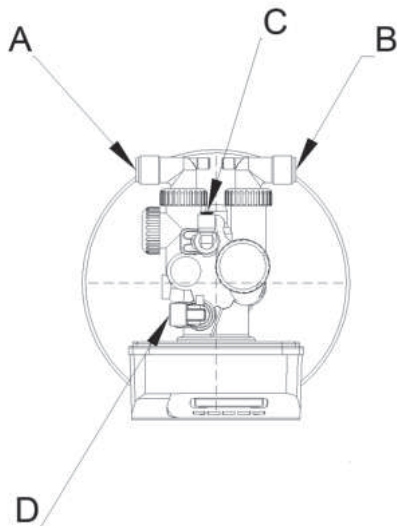

Marking	Nomenclature	Connection	Height
A	Outlet	PH G 1"	1395±30
B	Inlet	PH G 1"	
C	Brine line	PH G 3/8"	1545±30
D	Drain	PH G 3/4"	1555±30

## DIMENSIONS OF SYSTEM

