

## ECOSOFT POWERSOFT 2500

Treatment of household water, steam boiler and heating circuit feed water, pharmaceutical manufacturing, food processing, chemical manufacturing, textile industry, drinking water bottling, agriculture, fish farms etc.

### KEY FEATURES

- Minimum pressure losses on filters at maximum flows
- High flow lead free brass valve, high flow bottom laterals distributors, top stacks distributors, high capacity brine tank
- PC003UN for industrial softening applications: monodisperse size, gel, strong acid cation exchange resin
- Automatic Clack CE control valve:
  - Regeneration control by water volume: delayed regen, immediate, both
  - Possibility to change the cycle of regeneration stages and their range of time
  - Multilanguage menu: English, German, French, Ukrainian
  - Different setting modes are available:
    - double valve twin or duplex configurations
    - multi-system mode, up to 8 system to the system controller
    - 2 external devices simultaneously can be connected



### SET OF EQUIPMENT

#### WS1.5CE meter control valve assy (V15CEDTH):

- WS1.5CE control valve
- Top stack distributor, 50 mm riser
- Meter assembly
- Power supply
- Injector
- DLFC
- Funnel
- Valve instruction manual, Instruction manual

#### Pressure tank assembly:

- Pressure tank CN-21×62 (top bottom opening 4"-8-UN)
- Riser DN 50 mm
- Lateral bottom stack distributor

#### Brine tank assembly

- Brine tank 24×50, 378 L
- Brine well assembly (brine valve, overflow set)
- Brine grid

#### Resin

- Type resin — PC003UN monosphere cation exchange resin
- Volume resin — 250 liters

## TECHNICAL SPECIFICATION OF POWERSOFT 2500

Parameters	
Maximum service flow rate	13.4 m <sup>3</sup> /h
Quantity of resin	250 l
Volume capacity*	50 m <sup>3</sup>
Usage of salt per regeneration	25.0 – 40.0 kg
Usage of water per regeneration (= discharge per regeneration)	1.75 – 2.5 m <sup>3</sup>
Duration of regeneration	80 – 120 minutes
Operating pressure	2 – 6 bar
Inlet, outlet	1.5"
Drain	1"
Brine line	½"

Parameters	
Volume of pressure tank	311 l
Dome volume	25 l
Volume of brine tank	378 l
Dry system weight	55 kg
Electrical requirements	230 V, 50 Hz
Electrical power	30 W
Operating temperature	+4...+30 °C

## ECOSOFT POWERSOFT 2500

Code	Product	Volume resin, L	Maximum service flow rate, m <sup>3</sup> /h**
FU2162CE15	Ecosoft PowerSoft 2500	250	13.4

\* At a hardness of 250 ppm CaCO<sub>3</sub>, the salt dose for regeneration is 100 g/l

\*\* With a linear filtration rate of 60 m/h

## ACCESSORIES\*

Code	Description
V3009	WS2 Auxiliary Microswitch assembly
V3097BSPT	Bypass shut-off valve during regeneration (no-Bypass valve) 1.5" systems
V3071BSPT	Water Specialist 1.5" Motorized Alternating valve

\* Not included in the basic set.  
Can installed as additional equipment

## PRESSURE DROP vs FLOW RATE\*\*

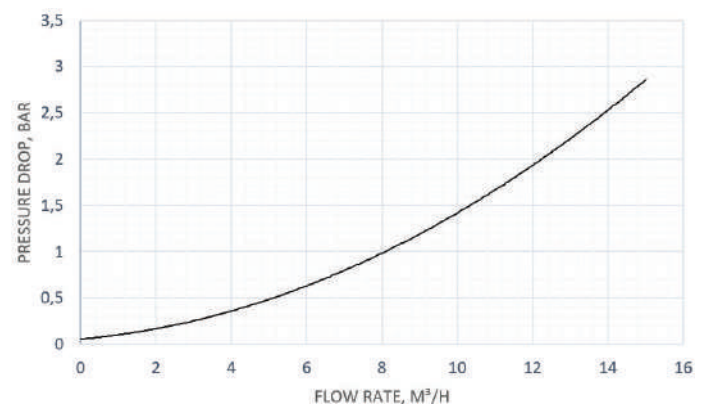

\*\* Data is based on control valve type, distributors type, temperature, and media type

## CONFIGURATIONS

### DOUBLE VALVE TWIN



#### DOUBLE VALVE TWIN ASSEMBLY PARTS

1. FU2162CE15 — 2 pcs.
2. V3071BSPT — 1 pcs.

Single valve twin set may operate 2 units with alternative mode (the first unit in operation, the second — in regeneration or stand by) and can produce water during the day at constant flow rate.

#### KEY FEATURES

- Ensures stable water quality with constant flow
- User friendly installation
- Doesn't create hydraulic shocks

### DUPLEX VALVE



#### DUPLEX VALVE ASSEMBLY PARTS

3. FU2162CE15 — 2 pcs.
4. V3071BSPT — 2 pcs.
5. 1PROVODDUP — 2 pcs.
6. V3009 — 2 pcs.
7. 71212 — 2 pcs.

Duplex valve set may operate 2 units parallel and can provide double flow rate during peak consumption.

#### KEY FEATURES

- Double flow rate for peak consumption
- User friendly installation
- Doesn't create hydraulic shocks

### MULTI-SYSTEMS



#### SET FOR 2...8 UNITS WITH CLACK SYSTEM CONTROLLER

1. FU2162CE15 — 2...8 pcs.
2. WSSYSTCON2\* — 1 pcs.
3. V3097BSPT — 2...8 pcs.

The Clack system controller may operate 2 – 8 units and has 4 operating modes that ensure efficient operation of the set for various needs.

#### KEY FEATURES

- System Controller may operate 2 — 8 units or be used as a water monitor only
- Clack WS1.0, WS1.25, WS1.5 or WS2 control valves may be used
- 4 available operating modes: Progressive flow, Alternator, Series, Random

**WSSYSTCON2\*** — includes a kit for connecting 2 systems. The last number indicates the number of possible connected systems

## CONNECTIONS

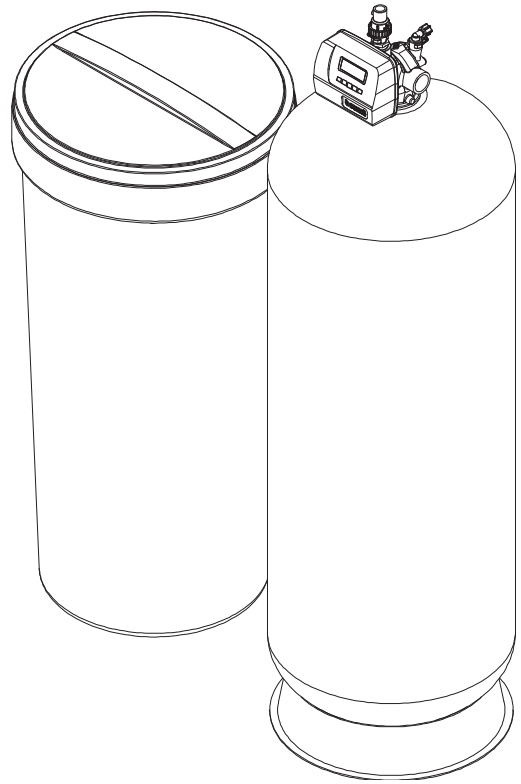
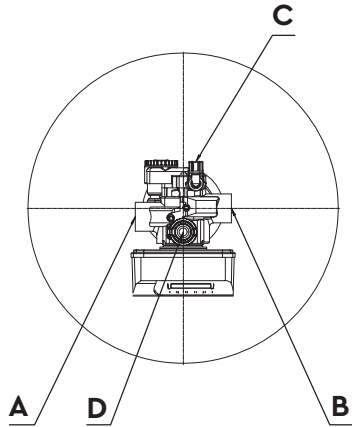

Marking	Nomenclature	Connection	Height
A	Inlet	PH G 1.5"	1815±30
B	Outlet	PH G 1.5"	1815±30
C	Brine line	PH G 1/2"	1925±30
D	Drain	PH G 1"	1970±30

## DIMENSIONS OF SYSTEM

