

ECOSOFT SMART WATER KEEPER 500

Water Keeper is a plug & play solution for water storage after commercial ROs and water supply to the consumer

APPLICATIONS

Private houses, water bottling shops, horeca, heating and cooling circuits, breweries and beverage production, livestock and poultry farms, glazing factories, laundry and car wash, greenhouses etc.

EQUIPMENT

- Filter BB-20 (with coconut shell carbon block filter 4.5"×20")
- Tank
- Pump Grundfos Scala 2 - 35
- Filter BB-20 (with coconut shell carbon block filter 4.5"×20")
- Ultraviolet lamp

KEY FEATURES

- Easy to connect
- Quickly connect
- Grundfos worldwide warranty on pump
- Modern design
- Integrated speed-controlled drive
- Extremely low-noise



PHYSICAL PARAMETERS

Volume, l/h	500,0
Rated flow rate*, m ³ /h	3,0
Rated head, bar	2.7
Approx. weight (bare system / in crate)	150 kg
Dimensions (bare system, H × W × D)	1.46 × 0.79 × 1.04 m

Feed water port	G 1"
Outlet water port	G 1"
Overflow water port	G 1"
Drain water port	G 1"



ESWB500 Ecosoft 500 liter water tank

Code	Model	Product	Volume, l	Pieces on pallet
ESWK500	ESWK500	Ecosoft 500 liter water tank	500	1

PIPES AND INSTRUMENTS DIAGRAM

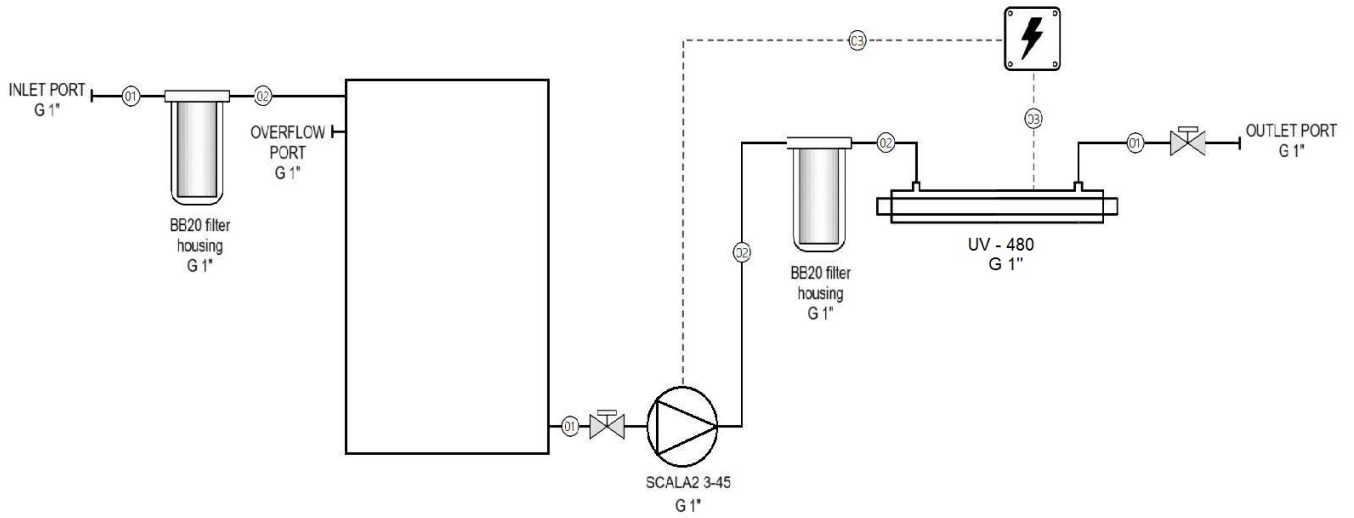
ECOSOFT SMART WATER KEEPER 500
Piping and Instrumentation Diagram



PIPES AND CONNECTIONS	VALVES	INSTRUMENTS
<ul style="list-style-type: none"> —(01)— PVC pipe 1" G parallel BSPT thread —(02)— Transparent PVC pipe 1" PVC polyvinylchloride (solvent weld) —(03)— Electrical cable 	 Valve	 Electrical panel

SYSTEM DIMENSIONS

